

Laminex<sup>®</sup>

# Kitchen Design & Renovation Guide

Simplifying the Process



# Your new kitchen starts here.

Since the rise of modern open plan living, the kitchen has become the undisputed heart of the home. Combining function and form, this hardworking room presents a meaningful space to cook, eat, entertain and for daily activities.

A kitchen remodel ranks high on the to-do list of homeowners. Research shows Australians spend around \$20,000\* on home kitchen renovations every year and the number of projects is on the rise. An investment of this scale requires careful planning and Laminex is here to support you every step of the way.

From budgeting to deciding on layout, our Kitchen Design & Renovation Guide walks you through the six stages of a successful renovation for the kitchen of your dreams.

---

## Contents

- 04 Step 01 — Planning
- 06 Step 02 — Budget
- 12 Step 03 — Storage & Layout
- 20 Step 04 — Style & Colour
- 24 Step 05 — Materials & Fixtures
- 30 Step 06 — Bringing it to Life

# Step 01 — Planning

The secret to a successful renovation lies in planning. Style, functionality and budget all play a part in the all-important planning process.

## 01 — Why are you renovating?

Start by determining a clear purpose for your project. Do you want to add value to your property for sale, or simply update to better suit your lifestyle? Understanding your reason for renovating will help you make the right decisions in the planning phase and beyond.

## 02 — Create a rough project schedule

Write a checklist outlining all the elements of your renovation and estimate how long each task will take to complete. Minor setbacks and changes are normal when renovating, so allow some room to move.

## 03 — Determine your budget

Consider the items on your checklist and roughly budget the amount you're able to spend on each. Prioritise items with the largest allocated spend at the beginning of the project, in case your budget becomes overstretched. Use the budget template in Step 02 as a guide for what to include.

## 04 — Be inspired

Spend time researching and curating reference images that communicate your style and goals. Pinterest, Instagram and magazines are the perfect places to find inspiration. Head to a showroom to feel inspired, motivated and gather ideas. Note the brands, materials and colours that make you feel connected and are appropriate for your project, gathering product swatches and samples as you go.

## 05 — Create a mood board

Visualise your future kitchen using the inspiration you've collected online, in print, and in showrooms. Create your perfect colour palette and watch your kitchen's style start to take form. Create a second mood board to compare. It will ensure you are confident with your selection.



## 06 — Outline your practical needs

For the most efficient space possible, ask yourself:

- Is your existing area large enough to move around comfortably, do you need to change the orientation of your existing kitchen or follow a similar layout?
- How much space do you require for storage and pantry goods?
- If using the bench as an eating area, how many people does it need to seat at once?
- Where will your waste, recycling and green waste be housed?
- What appliances need to be considered and where will they be stowed?

## 07 — Identify your project team

Identify who you might need to bring your project to life. Do you plan to use a kitchen designer, or are you planning on project managing yourself? Asking friends and neighbours to refer a designer and tradespeople they trust is a great way to build your project team.

### Expert tip: Write a brief prior to the renovation

Writing a succinct brief is essential for communicating your requirements to any designer, builder or trades person. Detail exactly what you are trying to achieve, scope of work, budget, project schedule, the existing elements staying or going, and other information you may need to refer to later.

## Planning checklist

Task	Done
01 — Why are you renovating?	
02 — Create a rough project schedule	
03 — Determine your budget	
04 — Be inspired	
05 — Create a mood board	
06 — Outline your practical needs	
07 — Identify your project team	

# Step 02 — Budget

Consider how much you want to invest in your kitchen. A set budget will inform the products and finishes that are most appropriate and help separate the essentials from the luxury items.

Kitchen renovation costs can vary, therefore, establishing a budget from the outset is essential.

Ask yourself these important questions to define whether your project is a low, mid-range or high-investment undertaking.

## Is this project a quick fix, renovation for sale, or your future dream kitchen?

A dream kitchen renovation warrants significant investment. Selling your home requires an inexpensive refresh and update for buyer appeal, which might include quick fixes, like refacing cabinets, painting and upgrading fittings.

## What exactly will you be spending money on?

List all the elements likely to incur costs over the course of your renovation, from design, consultations and products, to labour, demolition, waste removal and freight charges.

## How much are you willing to spend on your project?

If you have a budget set aside, divide this into stages to cover all elements of your project. Prioritise the areas most important to you.

## Will you need to make compromises?

If your kitchen renovation is part of a larger home improvement project, consider allocating or cutting costs in other areas for the best possible outcome for your kitchen.

## How important is energy efficiency?

Investing in energy efficient materials and appliances often require more investment upfront but can save you significant money long-term.

## Are you able to recycle materials, or retain your existing kitchen layout?

Moving plumbing or electrical fittings can blow out a budget. There may be tasks you can manage yourself, like painting and tiling. Complicated jobs, such as installing cabinetry, plumbing and electrical work should be left to skilled professionals.

## What can your budget realistically achieve?

Your answers to these questions will help you determine if you're able to undertake a low, mid-range or high-budget renovation. The following chart provides a general outline of what's achievable in each category.

Developing a clear overview of renovation costs ensures your project runs smoothly. Use the below template and average budget indication to guide your process to ensure you remain on budget. Always ask your supplier to advise in writing the components included in their quote.

### Expert tip: Budget clarity

Your budget will not only guide you in your selections of finishes and appliances, but also will help guide your architect, designer or cabinet maker. It will give them some knowledge to the best scope of works, types of finishes, and selections that they can recommend for that budget.

## Low (under \$15,000)

Cosmetic change only

Retain existing layout, no structural change

Sink & tap upgrade

New benchtops, cupboard doors and painted walls

Appliance upgrade – we recommend you hunt for a bundle sales package under \$3,000

Laminate cabinetry and benchtops are ideal

Essential trades

Project manage the renovations



Overhead cabinetry in **Laminex Delana Oak**, base cabinetry in **Laminex Possum**, benchtops and splashback in **Laminex Limed Concrete**

## Mid-range (\$15,000 - \$40,000)

Small structural update

Consider working with a kitchen renovation specialist or cabinet maker for new cabinetry, benchtop, splashback and fittings

If space allows include a walk-in pantry and appliance cupboard

A range of benchtop solutions are possible in the price range from premium laminate finishes to mid-tier stone

A reputable appliance package with some added features

Hire professional installers

Replace floor (e.g.: tile or laminate)



Island Benchtop & rear base cabinetry in **Laminex AbsoluteMatte Terril**, rear benchtop & splashback in **Essastone Unique Calacatta**, tower cabinetry in **Laminex AbsoluteMatte Oyster Grey**, overhead cabinetry in **Laminex Luscious Elm**

## High (\$40,000+)

You can start over with this type of budget

Use a professional kitchen designer and project manager to manage the build, including appointing contractors and tradespeople

New layout to maximise your space and functionality, including structural changes

If space allows add a butler's pantry

Add some extra personalisation in the selection of the splashback, fixtures and fittings including drawers and storage elements

Statement benchtop; stone, porcelain, polished concrete, marble, timber

Premium Cabinetry such as, Premium Gloss or Matte laminate, or Painted Cabinetry with profile details

European appliances, with 90cm not 60cm cooktops

Consider additional elements such as a double oven, steamer, bespoke rangehood or extra deep benches

Custom cabinet build & installation

Overhead feature lighting



Benchtop and splashback in **Essastone Luna Concrete** and cabinetry in **Laminex Black Birchply**

**Expert tip:  
Hidden costs**

Allow room for error with some contingency in your budget, around 15%, in case of the unexpected. Common issues that can occur are:

- Discovering outdated plumbing or electricals
- Discovering unsafe old materials
- Poorly completed DIY jobs that require professionals to fix
- Damp or termites
- Taking incorrect measurements

Developing a clear overview of renovation cost will help your project run smoothly. Use the below template and average mid-range budget indication to guide this process, ensuring your budget remains in place throughout. Depending on your project management approach, your designer or cabinet maker can guide you on this. If you are self-managing the project, start creating your list of suppliers and get rough quotes to build out your budget.

**Budget Template**

Your overall budget \$

Activity	Budget	Actual Cost	Difference
Design consultation			
Project documentation			
Demolition			
Rubbish removal			
Cabinetry installation			
Carpenter			
Electrician			
Plumber			
Plasterer			
Tiler			
Flooring			
Lighting			
Appliances			
Benchtops			
Cabinetry			
Handles			
Splashback			
Corking			
Painting			
Sealing			
<b>Totals</b>			

# Step 03 — Storage & Layout

A functional kitchen is essential. Practical considerations for storage and task zones will help you create a space that is a pleasure to use.

## Storage

### Food

Storage for consumable goods includes your pantry, fridge and freezer. Consider the position of both in your space. Divide your pantry into zones to ensure easy access to all items. Identify food and cooking categories, and designate a space for each.

### Utensils & Flatware

Utensils are best kept in shallow drawers in organisers, cooking implements are useful stored near to the cooktop.

Crockery and glassware stored in drawers makes them easier to access and saves space. Alternatively display flatware on plate racks or open and floating shelves. Space for large platters and glassware should also be considered.

### Cleaning products & equipment

Utilise storage space around the sink area for washing-up items. Larger items, like stick vacuum and brooms, can be kept in a tall designated cupboard in kitchen or butler's pantry. Ensure there's a power point where it is stored and a wall mounted tool holder for hanging your broom.

When choosing bins, consider the types you use and the most convenient location. Use separate bins or inner dividing systems.

### Food preparation

Ensure there is plenty of surface space to work on. Key areas are next to sink and cooktop and on island bench.

### Cooking & baking

Store pots and pans in deep drawers beside the cooktop and stash lids separately. Store cooking essentials like olive oil, seasonings and spices in a cabinet next to the cooktop, or in shallow drawers nearby.

## Pantry

### Choosing your perfect pantry

Your dream pantry is not only one that sits comfortably within your kitchen, but a space with designated homes for all your essentials. "Your pantry should suit your lifestyle," says interior designer Lauren Li. "Think about how you live, cook and entertain, and let your answers inform your choices."

### Expert tip: Pantry

Design for maximum space and optimum efficiency, with a layout and pantry fitted with clever storage solutions.

Consider:

- Location within your space
- Various shelf sizes and depths
- Installing a lazy susan or turntable to improve accessibility to back of cupboards
- Consider LED strip lighting; 'Install a release button so when the door opens the lights instantly flick on,' suggests Interior Designer, Lauren Li
- 'Determine a space for appliances and chargers and provide power points, plumbing and ventilation to suit,' says Lauren

### Pull-out pantry

A tall dedicated cabinet of any size located inside the kitchen.



### Corner pantry

Located in a corner with door extended fully to the floor, this pantry utilises an often-challenging section of the kitchen.



### Walk-in pantry

Located inside or outside the kitchen, this is a versatile option ideal for most layouts and budgets.



### Butler's pantry

The entertainer's dream, this pantry sits between the kitchen and dining room and is the perfect hiding spot for dirty dishes, utensils, glassware and appliances.

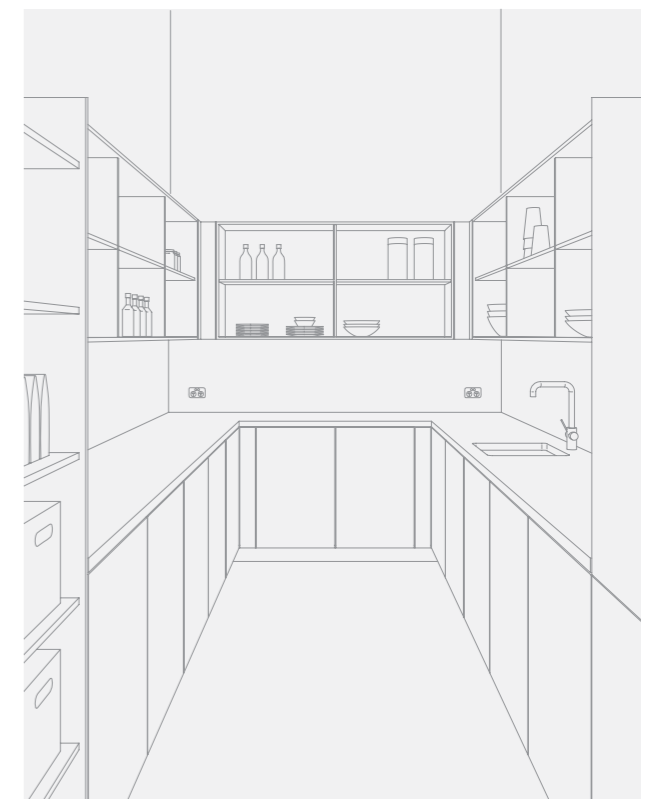

## Drawers

A well-designed layout incorporates multiple drawers in different styles to accommodate essentials, provide efficient storage, and enhance your time in the kitchen.

### Slide-out bench

Ideal for kitchens with limited food preparation space, they revolutionise the way you store essentials and how you cook.

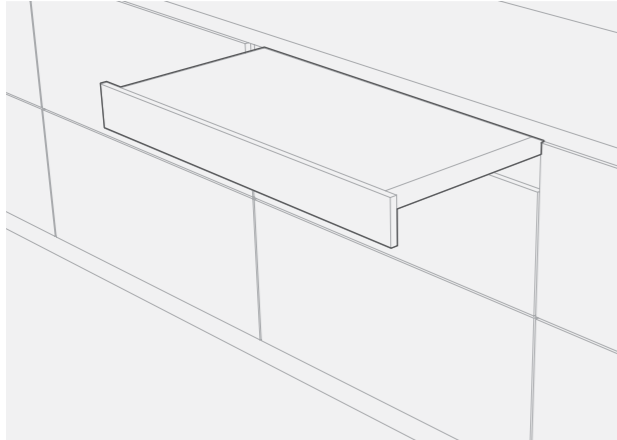

### Drawer dividers

Whether you are storing cutlery or pots and pans, they keep everything neat, tidy, visible and organised.

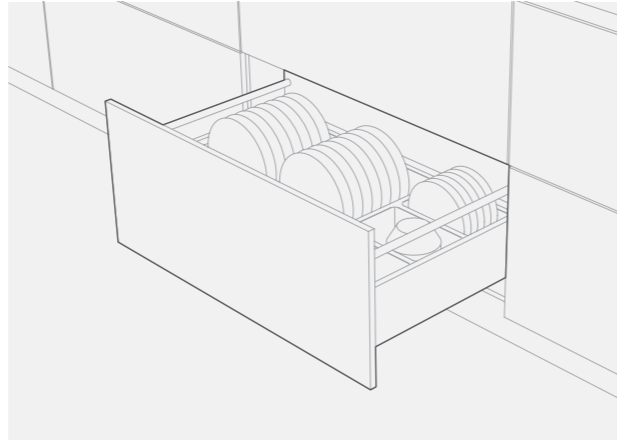

### Utility drawers

Keeps devices and portable gadgets charged and organised discreetly.

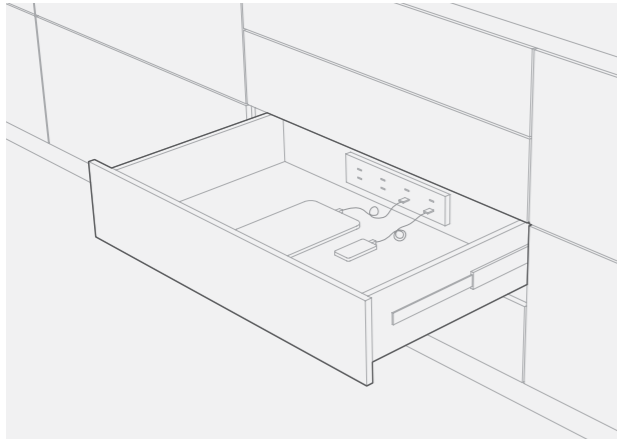

### Bin drawers

Integrate and divide bins so they are out-of-sight but convenient to reach.

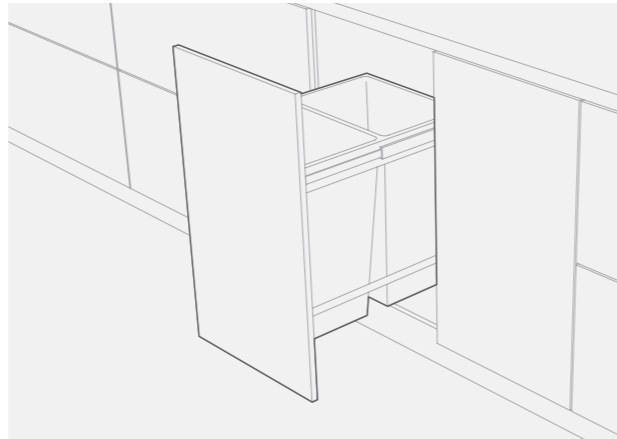

### Kicker drawers

Gain precious under cabinet storage space that is otherwise wasted.

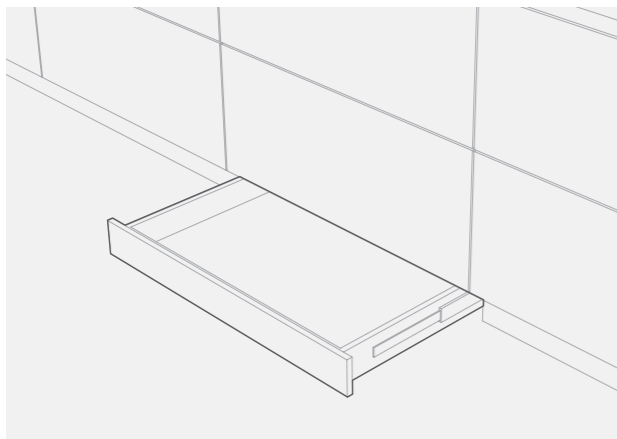

### Step Drawers

To help reach high overhead cabinets.

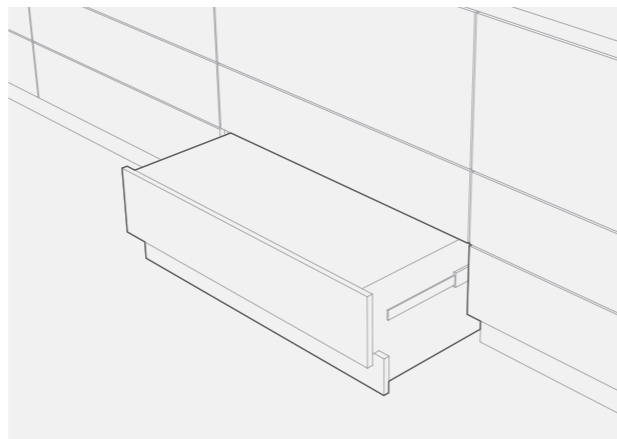

Benchtops & Splashback in **Essastone White Concrete** Matte finish, feature drawer fronts in **Laminex Impressions textured surfaces Seasoned Oak**, doors in **Laminex Calm White**, internal cabinetry in **Laminex Black**, designed by Kitchen Craftsmen and photographed by Dion Robeson





Benchtops & Splashback in **Essastone White Concrete** Matte finish, feature drawer fronts in **Laminex Impressions textured surfaces Seasoned Oak**, doors in **Laminex Calm White**, internal cabinetry in **Laminex Black**, designed by Kitchen Craftsmen and photographed by Dion Robeson

## Layout options

To determine your ideal layout, consider these questions:

- How do I use the kitchen on a daily basis?
- How does my family utilise this space?
- Will we eat meals here?
- How much storage do I require? Will this be hidden or on display?
- Will I entertain friends in the kitchen?
- Do I prefer open-plan kitchens or a separate space away from living and dining areas?

Take a look over the page at common floor plans to inspire your design.

### Expert tip:

#### Double check measurements.

—  
Is there room to open the oven door without tripping over it? Measure again to make sure. If DIY-ing, always follow the old adage, 'measure twice, cut once'.



Benchtop in **Essastone White Concrete** Matte finish, cabinetry in **Laminex Polar White**, photographed by Cathy Schusler, Est Living Project by Sian Macpherson

## Here are six kitchen layouts

### Island Kitchen

A popular kitchen style for a more social space, creating connection between your kitchen and open-plan living spaces. Providing additional work and storage space, this layout has the ability to adapt for a variety of spaces but is ideal for larger sizes.

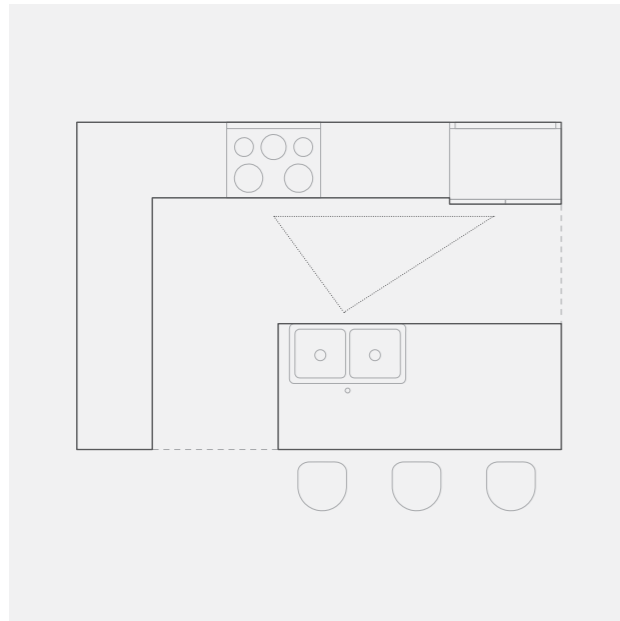

### L-Shape

Classic layout with vast design flexibility. Generous in space and is ideal for small to medium size spaces. Perfect for open plan living as it creates a natural openness to the space.

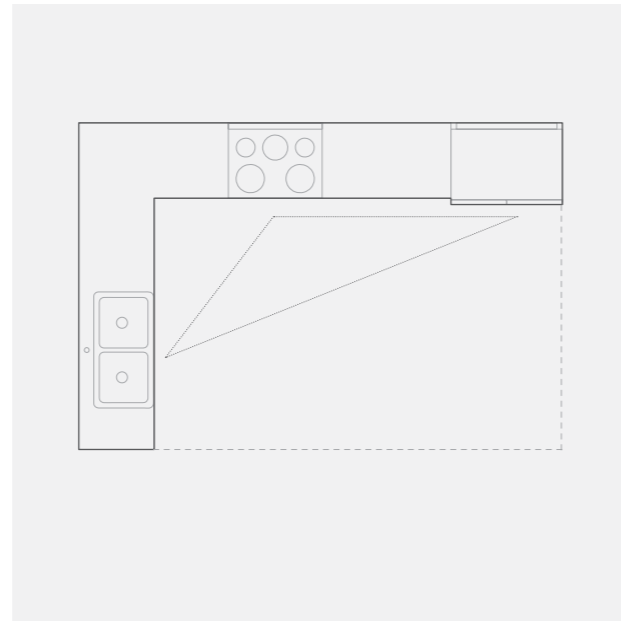

### U-Shape

Comprising of three walls with bench space and cabinetry, it provides various storage options and is ideal for medium-sized spaces. Perfect for incorporating a long island bench and integrating appliances, it allows clear sightlines into adjoining rooms.

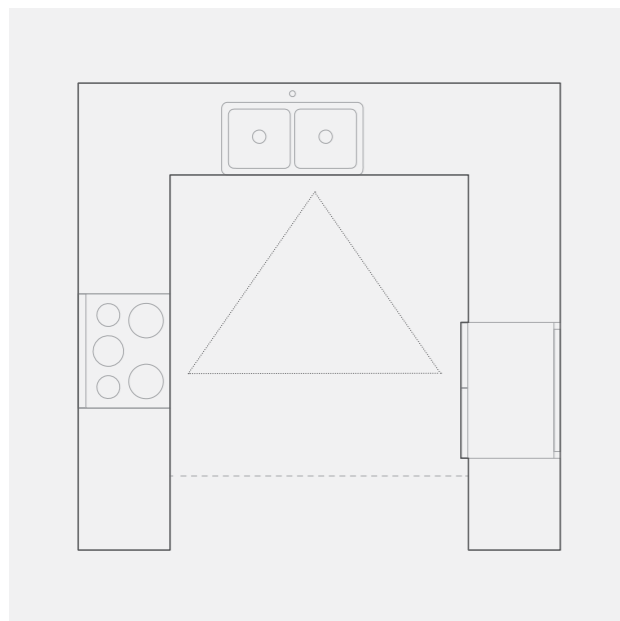

### G-Shape

A riff on the U-shape kitchen thanks to an added peninsula, this layout works in any space. Perfect for open plan homes, you will love its vast storage opportunities and generous surfaces.

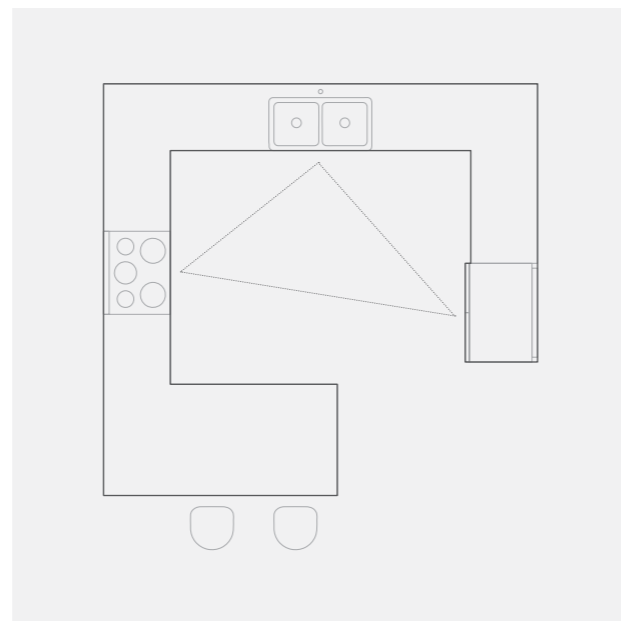

### One wall

The perfect format for a small space like an apartment. Run appliances and cabinetry along one wall for added spaciousness. With the sink, cooktop and refrigerator dominating the space, it can lack surfaces for food prep. Consider the use of integrated appliances such as an integrated cooktop.

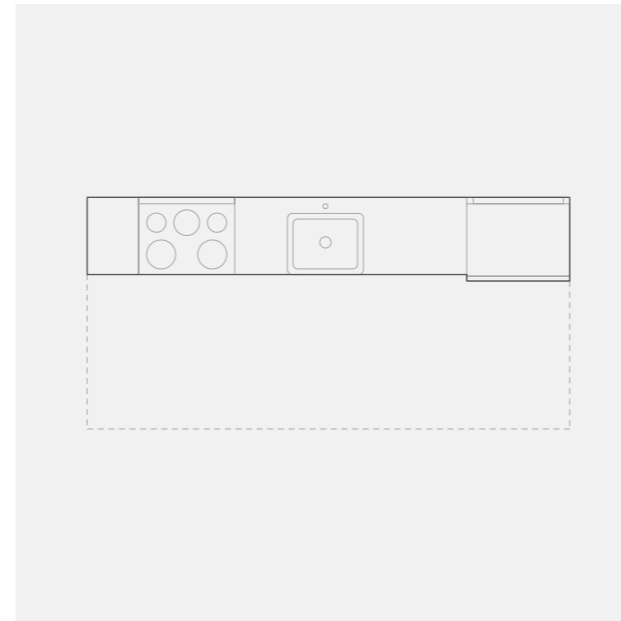

### Galley

Encompassing two parallel countertops with a walkway in-between, it is super compact making it a good choice for smaller homes. Everything you need is within arm's reach, so good organisation is vital. Storage can be scant so consider adding wall shelves.

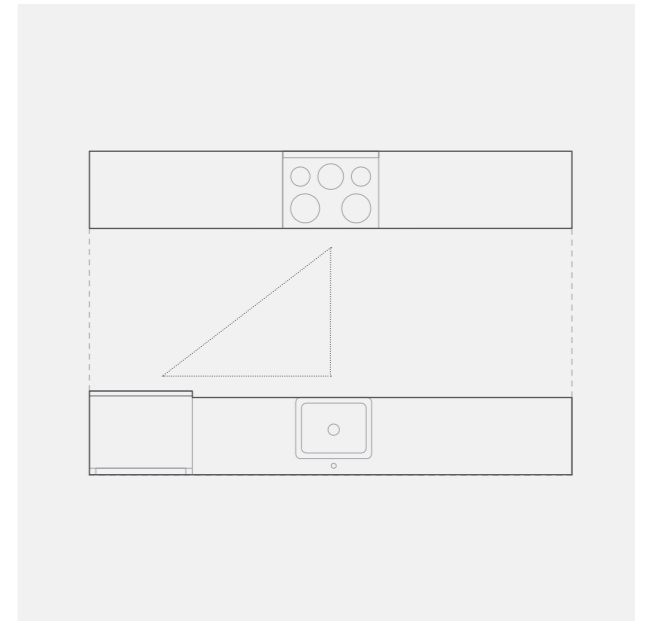

### Expert tip: Kitchen work triangle.

For optimal functionality, position fridge, cooktop and sink in the classic kitchen work triangle with an optimum distance of 1.2 and 2.7 metres between each. Before finalising layout, imagine cooking in this space and determine what works and what doesn't. Make adjustments to the arrangement until it feels comfortable and practical

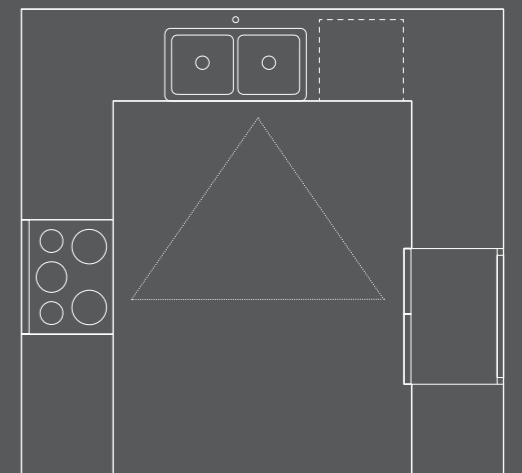

# Step 4 — Style & Colour

Because it is the heart of the home (and the best parties seem to start and end there), a beautiful kitchen is a must.

Whisking together the right ingredients, from its style to colour scheme, is the secret to a space that's as efficient as it is eye-catching.

Will your kitchen encapsulate classic timelessness or a more contemporary aesthetic? Find inspiration on Instagram, curate a Pinterest board, or thumb through your favourite magazines to create a mood board that will help you form its style.

If the kitchen is the only space in your home being renovated, consider how it will complement its existing scheme. Incorporate materials, colours or styles used in other rooms and adjoining spaces, for seamless flow and consistency.

## Colour palette

Your kitchen's style will inform its colour palette. While a classic home might feature elegantly simple and timeless shades, a contemporary space showcases more on-trend colours. Visit Laminex's online Inspiration Gallery to view a range of beautiful palettes and finishes, arranged according to style.

The most common home aesthetics can be broadly divided into contemporary, classic, and raw styles. Explore each one over the following pages.

### Expert tip:

#### Focal point

—  
Choose an existing focal point within your kitchen or create a new one to inform your overarching design scheme. It could be a pendant light, tiled splashback or flooring material.

### Expert tip:

—  
The colour selection should consider cabinetry, benchtop, splashback, flooring and paint colour.

## Contemporary

The new guard of contemporary design embraces softer edges, curves and clean lines. Unexpected elements epitomise this look, including minimalistic spaces, sparse yet bold use of colour and texture, and elements from the past reimaged in a fresh, new light.



Classic Oak Paper Bark French Cream

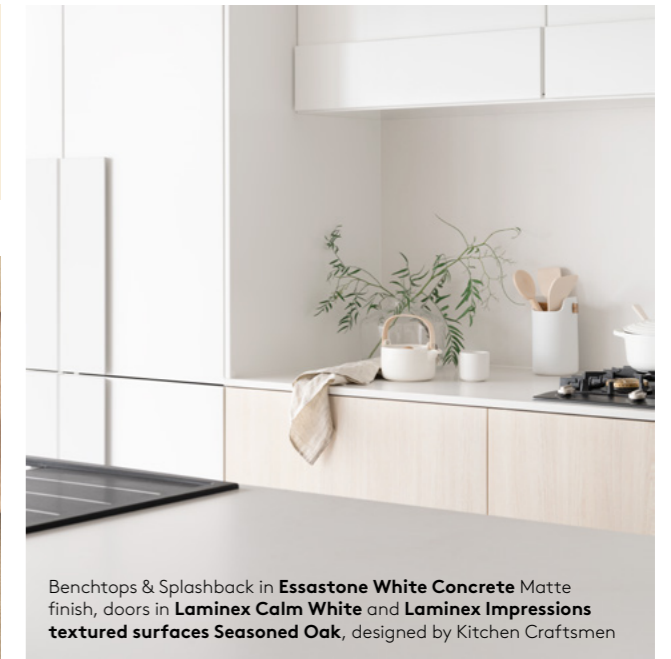

Benchtops & Splashback in **Essastone White Concrete Matte** finish, doors in **Laminex Calm White** and **Laminex Impressions textured surfaces Seasoned Oak**, designed by Kitchen Craftsmen



Decors in **Laminex Paperbark**, **Laminex French Cream** and **Laminex Whitewashed Oak**, designed by architect Kennedy Nolan



Decors in **Laminex Bayleaf** and **Laminex Honey Elm**, Designed by Lydia Maskiell

## Classic

An enduring style preference, this look honours established and timeless forms of beauty. Palettes in this scheme stand the test of time, work with a range of highlights and accessories, and are easily refreshed with new pieces.



Benchtops & splashback in **Essastone Marmo Bianco**, cabinetry and Island panels in **Laminex Formwrap** in **Pewter** Satin finish Settler Profile



Oyster Grey Unique Calacatta Fox Teakwood

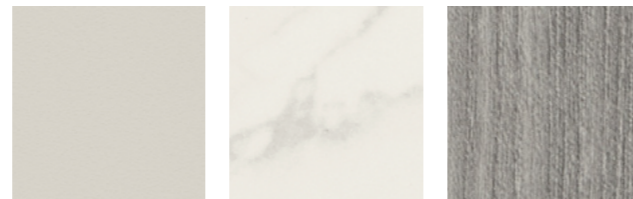

Pewter Marmo Bianco Brushed Brass

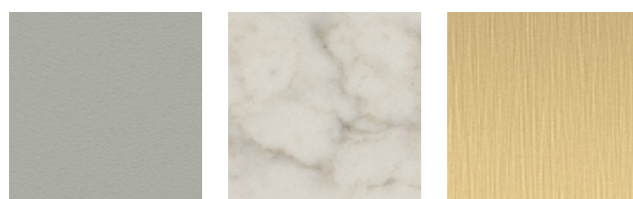

Benchtops in **Essastone Unique Calacatta** Honed finish, cabinetry in **Laminex FormWrap** doors in **Polar White** and **Battalion** Satin finish with a Settler profile, designed by Lydia Maskiell

## Raw

Raw interiors welcome the outside world in to create textured spaces with repurposed materials. A sense of organic beauty resounds and delivers warmth without pretension or over styling. Structural, industrial and natural elements are exposed, celebrating their true beauty.



Black White Grigio Grafite

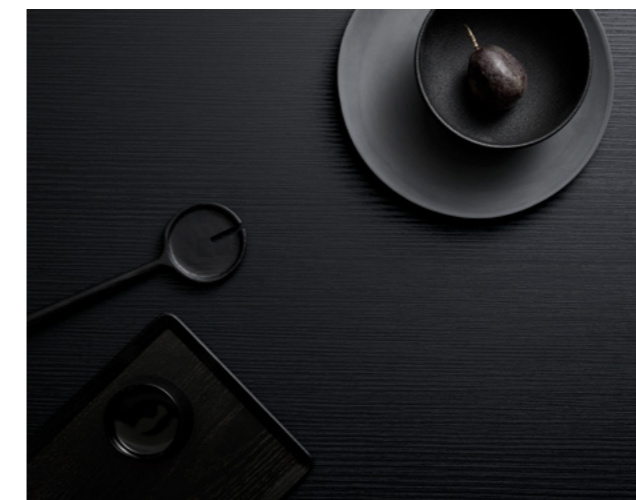

Decors benchtop in **Laminex Elemental Ash** 38mm, overhead cabinetry in **Laminex Lava Grey**, rear base cabinetry in **Laminex Black**

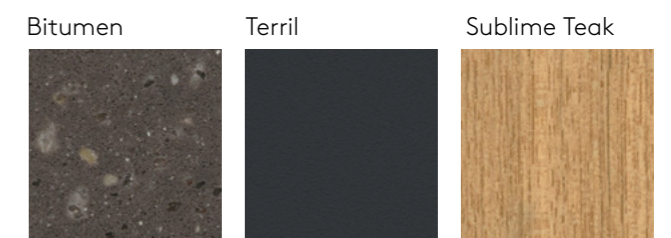

Bitumen Terril Sublime Teak



Island and rear benchtop in **Essastone Bitumen** igneous finish, base cabinetry in **Laminex White Textile**, overhead cabinetry and Island panel in **Laminex Impressions** textured surfaces in **Sublime Teak**



Benchtop surface in **Essastone Grigio Pezzato**

# Step 5 — Materials & Fixtures

Enhance your design scheme and colour palette with complementing materials and fittings. Balance personal style with practicality for a kitchen that's as useful as it is beautiful.



## Benchtops

The workhorse of the kitchen, the benchtop should be crafted from a robust and long-lasting material able to withstand daily wear-and-tear. Laminates are a more durable and less expensive alternative of stone and available in an extensive range of colours and finishes.



## Doors and panels

Surfaces, like cupboard doors and cabinetry panels, make a strong statement. Depending on how your space is constructed, it is possible for them to be updated without a full kitchen redesign. Laminex offers various product ranges, including DesignEdge, FormWrap, and ColourTech, that run across hundreds of decor styles to suit all styles and budgets.

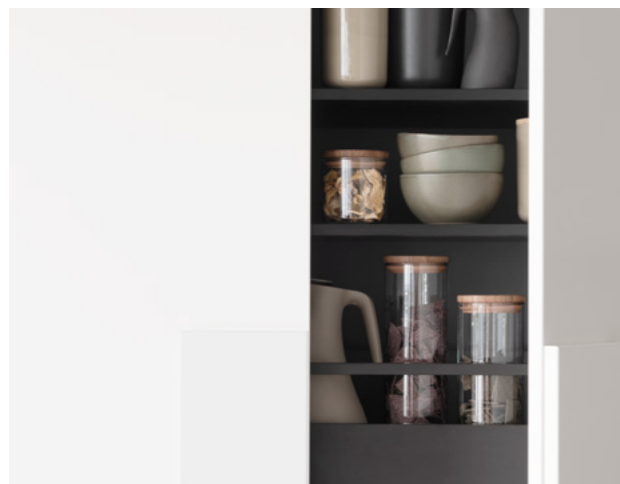

## Internal cabinetry

Apply crisp white, a neutral colour scheme, a woodgrain or pop of colour to the insides of your kitchen cabinets and make them a surprising hidden style feature. Be mindful that dark internal cabinetry may require additional lighting.



Base cabinetry in Laminex ColourTech Chalk White in a Country V profile, overheads in Laminex Colourtech Oyster Grey in Satin finish and Laminex Natural Walnut, benchtop in Laminex Grigio Grafite

**Expert tip:**  
**Select integrated elements early**

—

Before cabinetry is made and installed, confirm the plumbing products and appliances to be included. Your cabinet maker or builder will require this information in order to integrate cut-outs for elements like hoses, fittings and cavities. Complete this process early, so products can be ordered if needed.



**Splashback**

A focal point of your kitchen, the splashback also informs and ties together the entire space. Choose your favourite material from a range including tiles, glass, laminate surfaces and stone.



**Sink**

The sink is the central component of a kitchen's cleaning and utilities zone, where durability and performance are of utmost importance. Choose from a range including undermount, overmount, or an integrated style in stainless steel, acrylic or granite.



**Tapware**

Lifestyle and design schemes should be considered when deciding on tapware. For example, if you use large vases, pots or fill-up buckets in the kitchen sink, a pull-out gooseneck mixer is more practical than a normal mixer. Aesthetically, consider what colours, metals and materials will complement your space.



### Appliances

Performance, sustainability, aesthetics and convenience are key factors to consider when choosing appliances. Look for models that feature technological functions designed to make life less stressful, and energy-efficient products with sustainability and longevity.



### Lighting

Lighting fixtures can be applied in many areas of the kitchen, including inside cabinetry and over benchtops. One size does not fit all and a layering of products, including downlights and decorative pendants, is required to balance mood with functionality. If your budget can accommodate, consider consulting a specialised lighting designer.



### Flooring

The most impacted area of the home, kitchen flooring must be robust, durable and adaptable. Select colours and materials less susceptible to impact and spills, like tiles, laminate, timber and vinyl.

### Component Checklist

Component	Material	Colour	Supplier	Price
Benchtop – main				
Benchtop – other (pantry)				
Doors and panels – under bench				
Doors and panels – overheads				
Doors and panels – full height doors				
Internal cabinetry – standard				
Internal cabinetry – highlight				
Splashback				
Sink				
Tapware				
Appliances				
Lighting				
Flooring				
Handles				
				<b>Total \$</b>

#### Expert tip:

#### Lighting for mood and tasks

A good lighting plan includes task, ambient and decorative lighting.

Task lights allow you to prep and cook easily and safely.

Ambient light, achieved with dimmers, track and uplights, is used to impart warmth and highlight design features.

Decorative lighting makes a statement. Suspend a single or cluster of glass pendants over an island bench or table for the perfect finishing touch.

# Step 6 — Bringing it to Life

With planning and design elements in place, it's time to press go.

If working with a professional team, now is the time to engage your designer, builder or cabinet maker.

## Design process

- 01 — Finalise your mood boards
- 02 — Consult with designer and cabinet makers
- 03 — Engage designer, (or cabinet makers if project managing yourself)
- 04 — Measure and plan out your space

## Construction process

Once the plans are signed off, it's time for construction. Depending on the materials and scope of work involved, renovations generally occur in the following order.

- 01 — Demolition & removal of existing elements
- 02 — Rough-in plumbing & electrical work
- 03 — Painting
- 04 — Cabinetry install
- 05 — Benchtop install
- 06 — Splashback install
- 07 — Flooring install
- 08 — Connection of Electrical and Plumbing Fixtures

**Search the Locator Tool at [laminex.com.au](https://laminex.com.au) for cabinet maker, designer, and builder recommendations and showrooms in your area.**



Benchtop and island panels in **Marmo Bianco**



### **Design Stories**

To hear the latest design and product stories from us, sign up to our newsletter at [laminex.com.au](http://laminex.com.au)

### **Swatches & Free Samples**

To download high resolution Laminex swatches or to order free samples visit [laminex.com.au](http://laminex.com.au)

### **Call Us**

For customer service please call **132 136**

### **Follow Us**

 [facebook.com/Laminexau](https://facebook.com/Laminexau)

 [au.pinterest.com/Laminexau](https://au.pinterest.com/Laminexau)

 [instagram.com/Laminexau](https://instagram.com/Laminexau)

 [youtube.com/Laminexau](https://youtube.com/Laminexau)

LMX1765  
LAM5400 09/20

**Laminex**<sup>®</sup>



A proud  
Australian  
manufacturer